

# AQ70Z SENSOR

## Ozone (O<sub>3</sub>) Gas Sensor

### DOCUMENT PURPOSE

The purpose of this document is to present the performance specification of the AQ7 Series AQ70Z Ozone Gas Sensor.

This document should be used in conjunction with the AQ70Z Characterization Note and the Product Safety Datasheet (PSDS 5.4). For guidance on the safe use of the sensor, please refer to the Characterization Note.

The data provided in this document is based on the assumption that the sensor is used at 20°C, 50 %RH and 1013 mBar for three months from the date of sensor manufacture.

### APPLICATIONS

The AQ7 Series are for environmental applications; other applications, including industrial safety, may not be suitable.



Sensor Part Number: ASQ704-400

### FEATURES AND BENEFITS



High resolution



Low detection limit



Independent NO<sub>2</sub>  
cross compensation by  
using 4th electrode

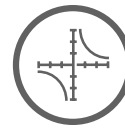

High correlation with  
control station



Individual compensation  
for temperature and  
cross sensitivity

# AQ7OZ Ozone Gas Sensor

TECHNICAL SPECIFICATIONS	
MEASUREMENT	
<b>Technology</b>	4-electrode electrochemical
<b>Measurement Range</b>	0 ppm O <sub>3</sub> to 1 ppm O <sub>3</sub>
<b>Maximum Overload</b>	5 ppm O <sub>3</sub>
<b>Sensitivity*</b>	500 nA/ppm ±200 nA/ppm
<b>Response Time (T<sub>90</sub>)</b>	≤ 120 seconds
<b>Resolution*</b> (when using recommended electronics)	5 ppb
<b>Baseline Offset*</b>	<±100 nA
<b>Repeatability*</b>	< ±5 % of signal
<b>Linearity**</b>	linear
<b>Low Detection Limit*</b>	5 ppb
ELECTRICAL	
<b>Recommended Load Resistor</b>	68 Ω
<b>Sensor Bias Voltage</b>	0 mV
MECHANICAL	
<b>Weight</b>	9 g
<b>Outer Plastic Body Material</b>	ABS
<b>Contact Material</b>	copper with gold coating
<b>Orientation Sensitivity</b>	none
ENVIRONMENTAL	
<b>Operating Temperature Range</b>	-30°C to 50°C (55°C intermittent***)
<b>Operating Humidity Range</b>	15 %RH to 90 %RH non-condensing
<b>Recommended Storage Temperature</b>	0°C to 20° in original sealed container
<b>Typical Applications</b>	ambient environmental monitoring
LIFETIME	
<b>Storage Life</b>	6 months in original sealed container
<b>Long-Term Sensitivity Drift*</b>	< 10 % signal loss per annum
<b>Expected Operating Life</b>	two years in air
<b>Warranty</b>	one year

\*Specifications are based on measurements made with cylinder gases using a flow rate of 500 ml/min and are valid at 20°C, 50 %RH and 1013 mBar using Honeywell recommended circuitry. Performance characteristics outline the performance of sensors supplied within the first three months. Output signal can drift below the lower limit over time.

\*\* Linear through the concentration range across the whole operational environment range.

\*\*\* Can be operated at 55°C for two hours (within the operating humidity range).

## Product Dimensions

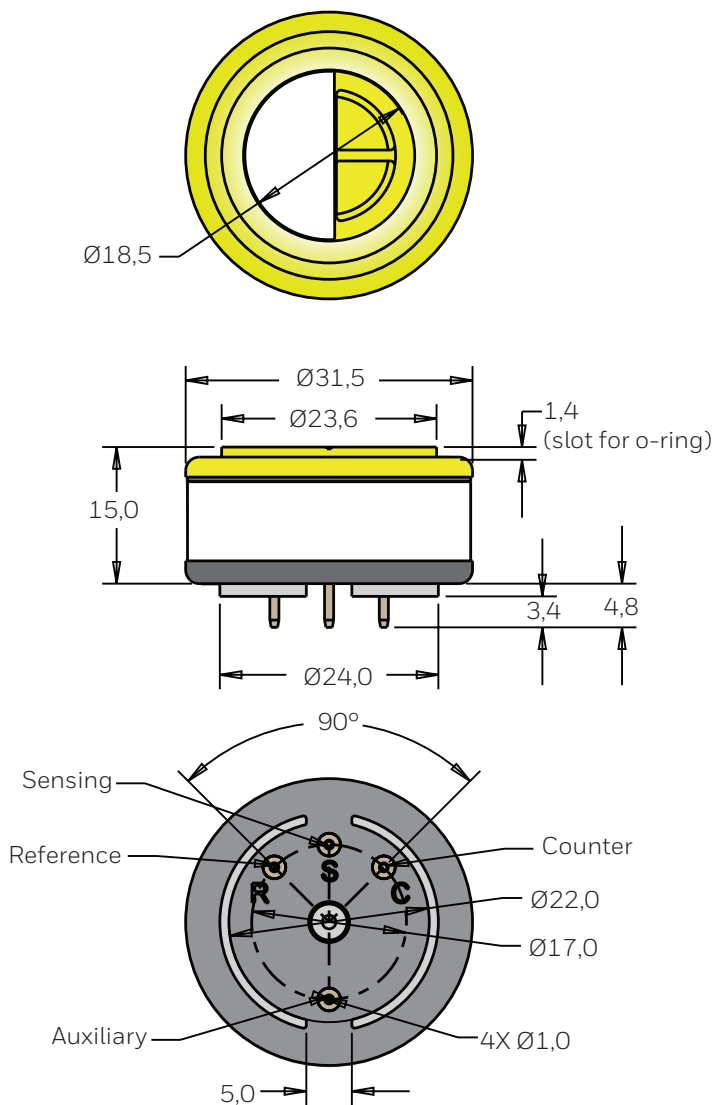

Dimensions mm  
All tolerances ±0,15 mm unless otherwise stated

# AQ7OZ Ozone Gas Sensor

## Poisoning

Gas sensors are designed for operation in a wide range of environments and harsh conditions. However, it is important that exposure to high concentrations of solvent vapors is avoided during storage, fitting into instruments, and operation.

When using sensors with printed circuit boards (PCBs), degreasing agents should be used before the sensor is fitted.

Do not glue directly on or near the sensor as the solvent may cause crazing of the plastic.

## Cross Sensitivity Table

Whilst AQ7 Series gas sensors are designed to be highly specific to the gas they are intended to measure, they will still respond to some degree to various other gases. The table below is not exclusive and other gases not included in the table may still cause a sensor to react.

**IMPORTANT NOTE: The cross sensitivity data shown below does not form part of the product specification and is supplied for guidance only. Values quoted are based on tests conducted on a small number of sensors and any batch may show significant variation. For the most accurate measurements, an instrument should be calibrated using the gas under investigation.**

Gas	Gas Concentration	Cross Interference
Carbon Monoxide (CO)	5 ppm	0 % < X % < 1 %
Nitrogen Dioxide (NO <sub>2</sub> )	1 ppm	0 % < X % < 15 % (after compensation)
Hydrogen Sulfide (H <sub>2</sub> S)	1 ppm	0 % < X % < 150 %
Sulfur Dioxide (SO <sub>2</sub> )	5 ppm	0 % < X % < 1 %
Isobutylene (C <sub>4</sub> H <sub>8</sub> )	1 ppm	None

## WARRANTY/REMEDY

Honeywell warrants goods of its manufacture as being free of defective materials and faulty workmanship during the applicable warranty period. Honeywell's standard product warranty applies unless agreed to otherwise by Honeywell in writing; please refer to your order acknowledgment or consult your local sales office for specific warranty details. If warranted goods are returned to Honeywell during the period of coverage, Honeywell will repair or replace, at its option, without charge those items that Honeywell, in its sole discretion, finds defective. **The foregoing is buyer's sole remedy and is in lieu of all other warranties, expressed or implied, including those of merchantability and fitness for a particular purpose. In no event shall Honeywell be liable for consequential, special, or indirect damages.**

While Honeywell may provide application assistance personally, through our literature and the Honeywell web site, it is buyer's sole responsibility to determine the suitability of the product in the application.

Specifications may change without notice. The information we supply is believed to be accurate and reliable as of this writing. However, Honeywell assumes no responsibility for its use.

## WARNING MISUSE OF DOCUMENTATION

- The information presented in this product sheet is for reference only. Do not use this document as a product installation guide.
- Complete installation, operation, and maintenance information is provided in the instructions supplied with each product.

**Failure to comply with these instructions could result in death or serious injury.**

## SAFETY NOTE

This sensor is designed to be used in environmental applications. To ensure that the sensor and/or instrument in which it is used, are operating properly, it is a requirement that the function of the device is confirmed by exposure to target gas (bump check) before each use of the sensor and/or instrument. Failure to carry out such tests may jeopardize the safety of people and property.

### Solent Gas Consultants Ltd.

Mobile: 07788 548013

Email: [solentgasconsultants@gmail.com](mailto:solentgasconsultants@gmail.com)

Website: [www.solentgasconsultants.com](http://www.solentgasconsultants.com)

**Honeywell**