

OP02 - Electrochemical Capillary Controlled Oxygen Sensors

CONTENTS

Introduction	2
Operating Principles	2
Linearity	3
Sensor Lifetime	4
Effects of Temperature, Pressure and Humidity	4
Effects of Rapid Temperature and Pressure Changes	5
Carrier Gas Effects	6
Cross Sensitivity	6
Sensor Mounting	7
Handling and Storage	7

Introduction

City Technology was founded in 1977 by a team of four scientists operating from a small backroom on the City University campus in London. The team had won a large contract for the first commercially viable electrochemical oxygen sensor and hence City Technology was born.

The commercial success of the sensor facilitated City Technology's investment into new markets and the subsequent development of a wide range of electrochemical gas sensors.

Operating Principles

All electrochemical oxygen sensors are of the self-powered, diffusion limited, metal-air battery type comprising a lead anode, electrolyte and an air cathode as shown below.

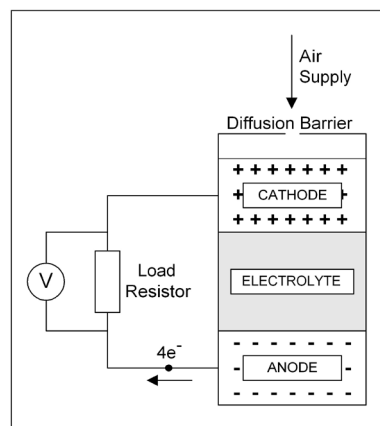

Oxygen Sensor Schematic

An oxygen cell can be considered as an enclosure which holds two electrodes: the cathode (a flat PTFE tape coated with an active catalyst) and the anode (a block of lead metal). This enclosure is air-tight apart from a small capillary at the top of the cell which allows oxygen access to the working electrode. The two electrodes are connected, via current collectors, to pins which protrude externally and allow the sensor to be electronically connected to an instrument. The entire cell is filled with a conductive electrolyte which allows transfer of ionic species between the electrodes.

The rate at which oxygen can enter the cell is controlled by the size of the capillary hole at the top of the sensor. When oxygen reaches the working electrode, it is reduced to hydroxyl ions according to the following equation:

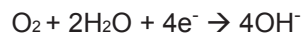

These hydroxyl ions migrate through the electrolyte to the lead anode, where they are involved in the oxidation of the metal to lead(II) oxide:



Overall the cell reaction may be represented as:

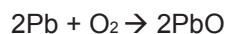

As the electrode reactions take place, a current is generated which is proportional to the rate of oxygen consumption (Faraday's Law). This current can be measured by connecting a resistor across the output terminals to produce a voltage signal. If the passage of oxygen into the sensor is purely diffusion limited, this signal is a measure of oxygen concentration.

The maximum voltage signal should not exceed 100mV. For most applications, a 100 Ohm load resistance is suitable (recommended load resistances are quoted in the product dataheets). As a general rule, the higher the load resistance the greater the response time of the sensor. However it is important to allow sufficient range in the calibration resistor to cover the variation in output current between sensors, as well as changes caused by temperature variations and an allowance for long term drift.

If an oxygen cell has been left off load for any length of time, then it must be placed on load and allowed to stabilise before an accurate calibration can be performed. The stabilisation time is dependent on the length of time the sensor was left off-load. However, up to 12-24 hours stabilisation time may be required.

Linearity

The sensor signal is slightly non-linear and follows the law:

$$S = K \log_e 1/(1-C)$$

N.B. If the sensor is calibrated in dry air to read 20.9% (S=20.9, C=0.209), then K = 89.14

In the example below the two lines are arranged to be the same at 20.9% oxygen which represents the condition when calibrating in air. The maximum error then occurs at about 10% Oxygen when the sensor output is approximately 0.5% lower than a linear response would indicate. In most circumstances this error is insignificant, although digital techniques may provide compensation if required.

Output Signal vs. Concentration

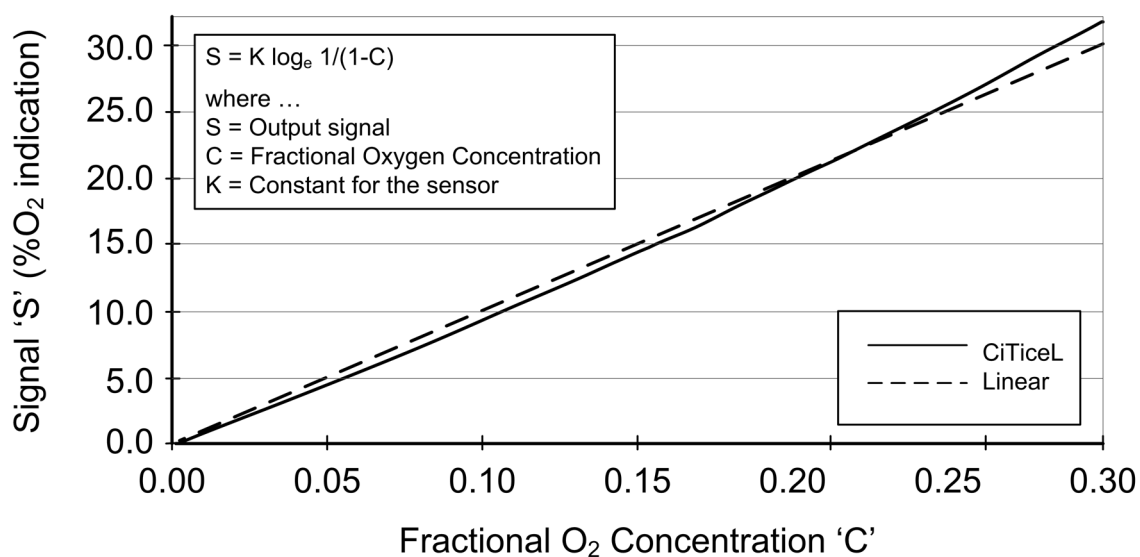

Sensor Lifetime

Oxygen CiTiceLs have a finite life, determined by the total exposure to oxygen. The fundamental operating principle of the oxygen sensor involves a lead anode which is oxidised when the sensor is on load. Once the lead is fully consumed, the sensor will no longer function.

An oxygen CiTiceL will have a stable signal output, which experiences minimal decline, right up until the end of its life. At the end of the sensor's operating life, there will be a sudden and rapid drop-off in output as the sensor's anode is finally consumed.

Effects of Temperature, Pressure and Humidity

Temperature Dependence

Sensor output varies slightly with gradual changes in temperature. The sensor output will increase slightly with increasing temperature, and will decrease slightly with decreasing temperature.

An example is shown below. This graph shows the temperature behaviour observed in tests carried out on a number of MICROceL OX sensors. The signal at 22°C is nominally set at 100%, and the signals at other temperatures are expressed as a percentage of the 22°C signal.

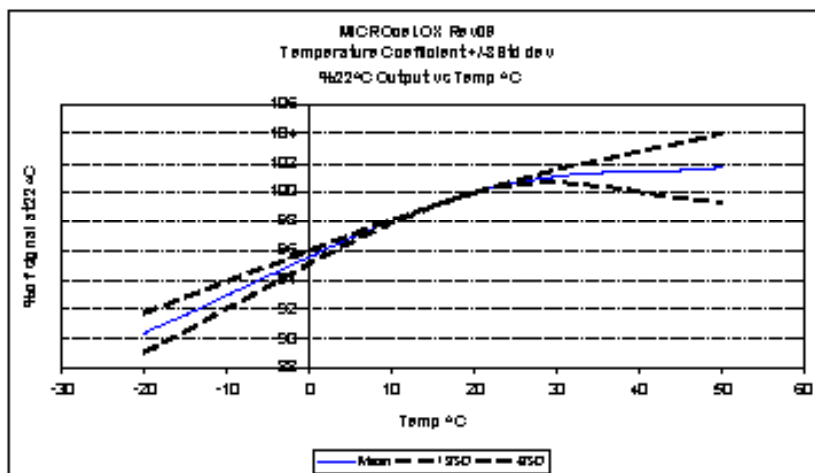

The behaviour shown above is typical of the MICROceL OX when subjected to gradual changes in temperature. Other oxygen sensors will exhibit a similar behaviour.

When exposed to a step change in temperature, oxygen sensors exhibit a transient response - a decrease in signal for a sharp rise in temperature and an increase in signal for a sharp drop in temperature. The transient temperature response will fall away after a short time (typically around 30 seconds). Further details regarding transient behaviour can be found in the Characterisation Notes.

These sensors are fairly resistant to damage from extremes of high or low temperature. Even so, the sensors must never be exposed to temperatures which will harm the components of the sensor.

Pressure Transients

Oxygen sensors give transient responses to step changes in pressure - an increase in signal for increased pressure and a decrease in signal for decreased pressure changes. This transient usually fades away after a short time. Further details regarding transient behaviour can be found in the Characterisation Notes.

A sensor may also give a temporary increase in signal if it receives a mechanical shock. These shock responses can largely be eliminated by using polythene foam or other suitable cushioning material as a padding around the sensor.

Humidity Effects

Changes in relative humidity of a gas sample will affect the volume % concentration of oxygen, and therefore the output of an oxygen sensor. As humidity increases a dilution effect is caused by increasing water vapour pressure. The current given by the sensor is only affected in as much as the concentration of oxygen varies. The graph below shows the change in oxygen concentration of ambient air over the range 0-100% RH at different temperatures.

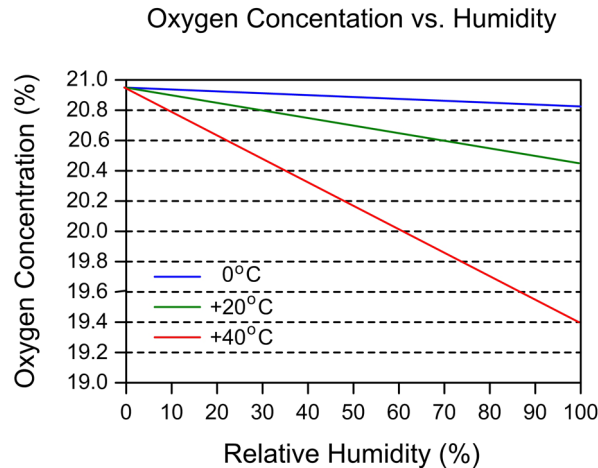

Oxygen sensors are largely unaffected by prolonged periods of operation in either extremely high, or extremely low relative humidity. It is only with high temperatures and extreme humidity together, that operational problems may occur during the normal working life of the sensor.

Conditions where liquid condensation may occur should be avoided. Under these conditions liquids may form in the region of the gas access hole, which will restrict the flow of gas to the sensor. With gas access restricted, a low signal will be given. If a sensor shows signs of being affected by condensation, normal operation may be restored by drying the sensor with a soft tissue. Under no circumstances should the sensors be heated to dry them out.

Effects of Rapid Temperature and Pressure Changes

During sudden changes in temperature or pressure, random signal spikes may sometimes be observed on the sensor output. These spikes are due to a sudden ingress (or egress) of air that can occur to equalise the pressure differential within the sensor caused by the temperature or pressure change. The resulting movement of oxygen and subsequent signal disturbance may result in instrument false alarms.

Inclusion of a vent hole on the back of the sensor eliminates the possibility of a pressure differential within the sensor, and subsequently prevents such effects from occurring. Note that not all oxygen sensors incorporate a vent hole.

IMPORTANT NOTE: When installing a vented sensor into instrumentation, blocking of the vent hole should be avoided.

Carrier Gas Effects

For most purposes, oxygen sensors may simply be calibrated in ambient air. In the presence of high concentrations of gases other than air, however, the effect of the carrier gas (i.e. mixture less oxygen) on the output signal becomes important.

The rate of diffusion of oxygen (and hence the signal from the sensor), is proportional to the molecular weight of the carrier gas (Graham's Law). Dry air may be considered to consist of 20.95% oxygen in nitrogen, which has a molecular weight of 28. When using the sensor with a different carrier gas, with a significantly different molecular weight from nitrogen, the signal from the sensor will be affected. The difference in signal to the nitrogen standard may be calculated using the following:

$$\text{New signal} = \text{Signal with nitrogen carrier gas} \times (28 / M)^{1/2}$$

Where :-
28 = molecular weight of nitrogen
M = mean molecular weight of carrier gas

Example

If the sensor is working in a carrier gas consisting of 60% nitrogen (molecular weight: 28) and 40% helium (molecular weight: 4) the mean molecular weight of the carrier gas is:

$$((28 \times 60) + (4 \times 40)) / 100 = 18.4$$

Hence:

$$\begin{aligned} \text{New signal} &= \text{Signal with nitrogen carrier gas} \times (28 / 18.4)^{1/2} \\ &= \text{Old signal} \times 1.23 \end{aligned}$$

Carrier gas mixtures having a mean molecular weight significantly different from nitrogen will require a special calibration test gas, due to the effect this has on the output signal.

Cross Sensitivity

Toxic gases at TLV levels will have no cross-sensitivity effect on Oxygen CiTiceLs. At very high levels (i.e. percent levels), highly oxidising gases (e.g. ozone and chlorine) will interfere to the extent of their oxygen equivalent, but most other commonly occurring gases will have no effect. For example:

Methane 100%	0
Hydrocarbons 100%	0
Hydrogen 100%	< -2%
Carbon monoxide 20%	< -0.5%

Acid gases such as CO₂ and SO₂ will be slightly absorbed by the electrolyte and tend to increase the flux of oxygen to the electrode. This gives an enhanced oxygen signal of about 0.3% of signal per 1% CO₂. Capillary controlled CiTiceLs are not suitable for continuous operation in concentrations of CO₂ above 25%. In applications where high concentrations of CO₂ are present, the AO2 CiTiceL is recommended.

Sensor Mounting

Oxygen sensors are only sensitive to orientation to a small degree and can be mounted in any orientation with minimal effect on performance.

IMPORTANT NOTE:

- Sensor pins must not be soldered to, as excessive heat will damage the sensor.
- The vent hole must not be blocked, as this may result in the glitching of the sensor.

Handling and Storage

CiTiceLs are relatively insensitive to mishandling and following the simple guidelines given below should ensure correct operation.

- CiTiceLs may be stored for up to six months, during which time they should be kept sealed in the container in which they were supplied or in clean air and within the temperature range given on the product data sheet.
- CiTiceLs should not be stored in areas containing solvent vapours.
- It is important to be aware that reactive species can diffuse into and reside un-reacted on a CiTiceL until the instrument they are in is switched on and the sensor is operational. Once powered, the resulting reaction can cause a temporary high baseline.
- It is important to avoid using CiTiceLs in close proximity to alcohol containing antiseptic products, such as wipes and sanitizing gels, or handling CiTiceLs if these products have recently been used. CiTiceLs can respond to the alcohol based solvents contained within these and generate an output, which could manifest itself as an exaggerated baseline signal or prolonged recovery time.
- CiTiceLs must not be subjected to any pressure when handling or clamping.
- At the end of its life, please dispose of CiTiceLs in accordance with local regulations. The hazardous waste disposal regulations depend on geographic location, and local regulations should be checked before discarding sensors. Product Safety Datasheets (PSDS's) are available for all City Technology products, detailing their hazardous content.

Every effort has been made to ensure the accuracy of this document at the time of printing. In accordance with the company's policy of continued product improvement City Technology Limited reserves the right to make product changes without notice. No liability is accepted for any consequential losses, injury or damage resulting from the use of this document or from any omissions or errors herein. The data is given for guidance only. It does not constitute a specification or an offer for sale. The products are always subject to a programme of improvement and testing which may result in some changes in the characteristics quoted. As the products may be used by the client in circumstances beyond the knowledge and control of City Technology Limited, we cannot give any warranty as to the relevance of these particulars to an application. It is the clients' responsibility to carry out the necessary tests to determine the usefulness of the products and to ensure their safety of operation in a particular application.

Performance characteristics on this data sheet outline the performance of newly supplied sensors. Output signal can drift below the lower limit over time.